

SINGLE-SEAL EXPANSION JOINT

Floor to Floor | Floor to Wall

30 - 75 mm (1 1/4 - 3") Expansion Gaps

MaxAtec 120 : A01-A02

MaxAtec 120 : A01

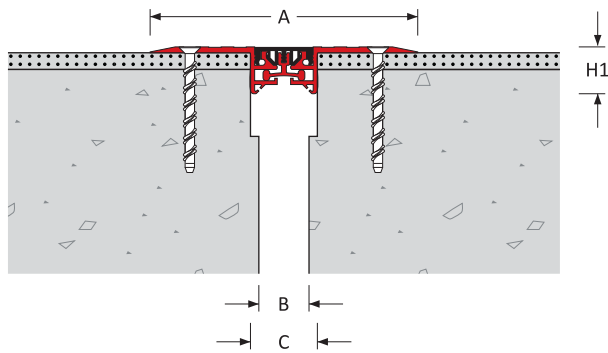

MaxAtec 120 : A02

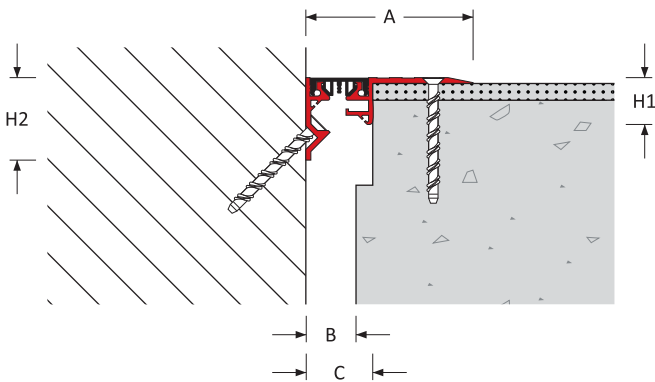

Expansion Joint Selection Criteria

Load Rating

Product Details

Joint Location	Gap Width B(mm)	Movement Capacity (mm)		Eurocode Rating				Product Dimensions				Product Number
		±	[Total]					Height		Sightline	Blockout	
								H1 (mm)	H2 (mm)	A (mm)	C (mm)	
Floor - Floor	30	± 5	[10]	5 kN	46 kN	-	-	27	-	160	40	120-A01-030
	50	± 10	[20]	2 kN	31 kN	-	-			191	71	120-A01-050
	75	± 15	[30]							213	93	120-A01-075
Floor - Wall	30	± 5	[10]	5 kN	46 kN	-	-	27	50	100	40	120-A02-030
	50	± 10	[20]	2 kN	31 kN	-	-		75	131	71	120-A02-050
	75	± 15	[30]						153	93	120-A02-075	

Features

Surface

Smooth surface

Surface mounted

Centre supported and Americans with Disabilities Act (ADA) compliant across the entire movement cycle

Movement

Good movement capacity

ASTM E-1399 Class I: Thermal

Class II: Wind

Traffic Frequency per day

				
≤ 25,000	≤ 10	≤ 10	-	-

System Options

Gap width(s)	30, 50, 75 mm
Height(s)	27 mm
Metal type(s)	Aluminium
Seal colour(s)	Black, Grey, Stone
Fire barrier	120-240 minutes
Waterproofing	Moisture barrier
Pre-assembly in factory	Contact Vexcolt

MaxAtec 120 : A01-A02



APPLICATIONS

Airport Terminals | Educational | Exhibition Centres
Department Stores | Distribution & Retail Warehouses
Factories | Hospitals | Museums | Offices & Hotels
Parking | Places of Worship | Residential Buildings
Rail, Metros & Elevated Rail Stations | Roads & Bridges
Shopping Centres | Sports Stadiums | Supermarkets