

METAL EXPANSION JOINT

Floor to Floor

25 - 50 mm (1 - 5") Expansion Gaps

MegAtec 330 : S01-S02

MegAtec 330 : S01

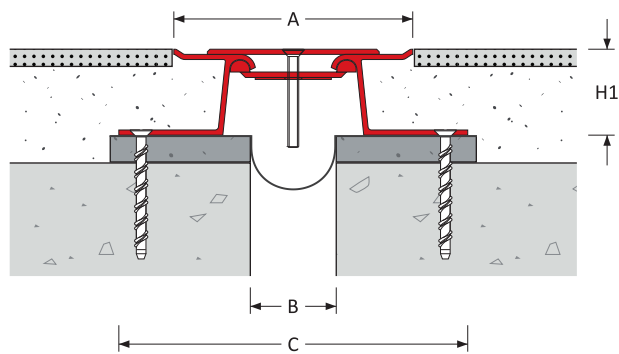

MegAtec 330 : S02

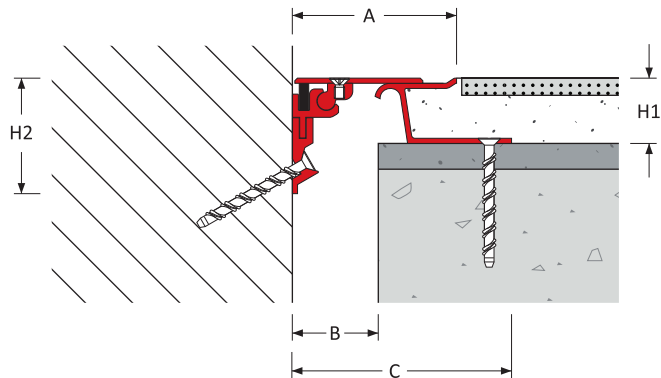

Expansion Joint Selection Criteria

Load Rating

Product Details

Joint Location	Gap B	Movement Capacity (mm)		Eurocode Rating				Product Dimensions			Product Number	
		±	[To-					Height		Sight-A		Block-C
Floor - Floor	25	± 12	[25]	2 kN	31 kN	-	-	25: 38: 50	-	127	191	330-S01-025-(H1)
	50	± 25	[50]	-	-	-	-			139	203	330-S01-050-(H1)
Floor - Wall	25	± 6	[12]	-	-	-	-	25: 28: 50	67	90	122	330-S02-025-(H1)
	50	± 12	[25]							96	128	330-S02-050-(H1)

When specifying or ordering please add the **height (H1)** required to the Product Reference.
For example MegAtec 330 : S01-050-038 denotes a joint 38mm high.

Features

Surface

80-grit surface finish to stainless steel for improved slip resistance
Americans with Disabilities Act (ADA) compliant
across the entire movement cycle

Movement

High movement capacity
ASTM E-1399 Class I: Thermal
Class II: Wind

Traffic Frequency per day

				
≤ 10,000	≤ 100	≤ 10	-	-

System Options

Gap width(s)	25, 50 mm
Height(s)	25, 38, 50 mm
Metal type(s)	Aluminium Stainless Steel Top Plate
Seal colour(s)	No seal used
Fire barrier	120-240 minutes
Waterproofing	Moisture barrier
Pre-assembly in factory	Contact Vexcolt

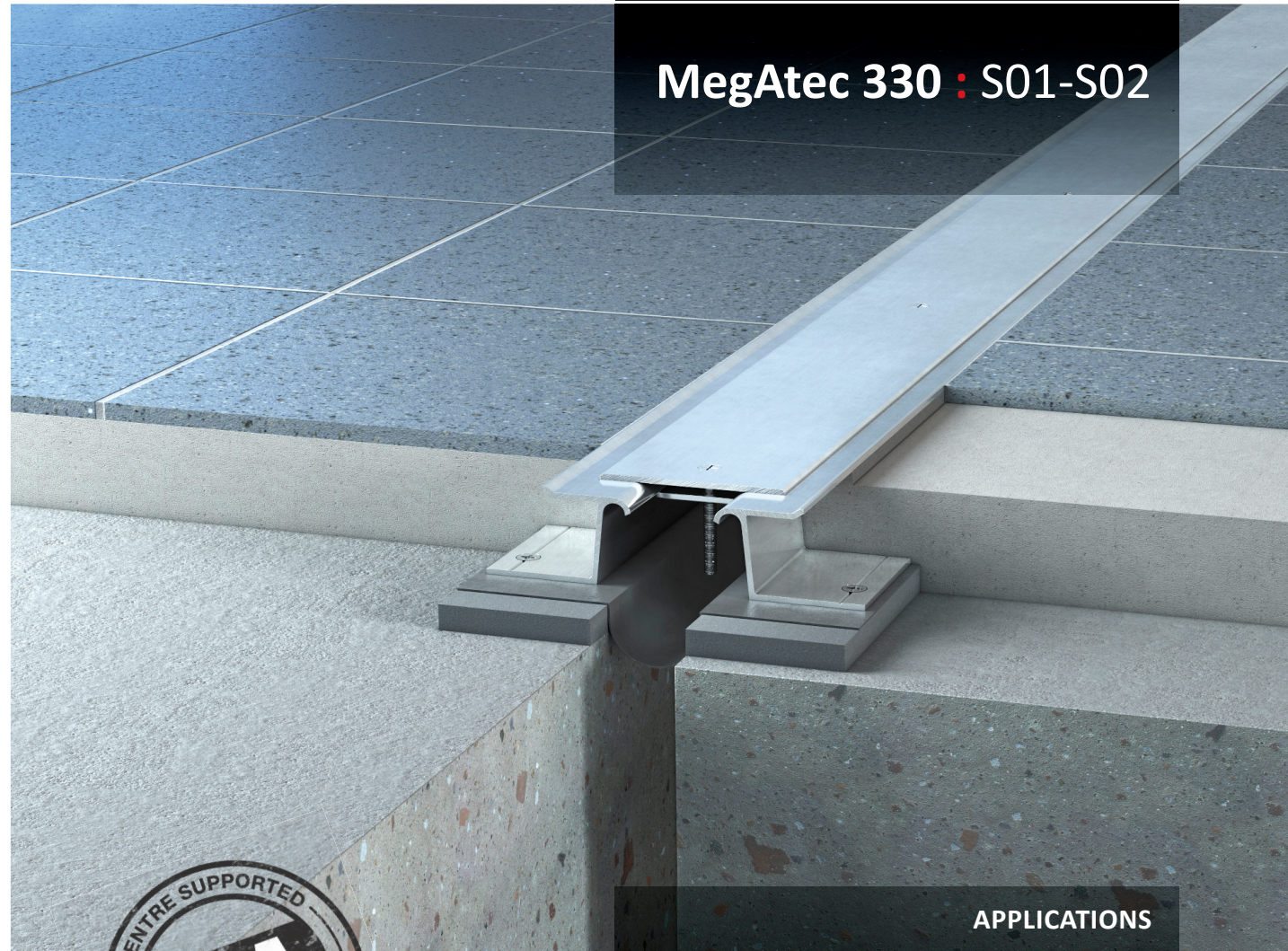

MegAtec 330 : S01-S02



APPLICATIONS

Airport Terminals | Educational | Exhibition Centres
Department Stores | Distribution & Retail Warehouses
Factories | Hospitals | Museums | Offices & Hotels
Parking | Places of Worship | Residential Buildings
Rail, Metros & Elevated Rail Stations | Roads & Bridges
Shopping Centres | Sports Stadiums | Supermarkets