

METAL EXPANSION JOINT

Floor to Floor

25 - 300 mm (1 - 12") Expansion Gaps

MegAtec 340 : S01-S02

MegAtec 340 : S01

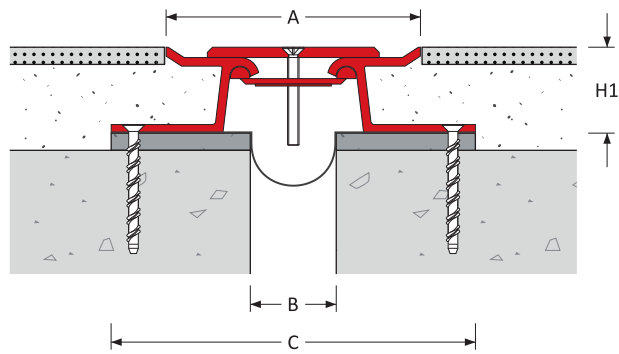

MegAtec 340 : S02

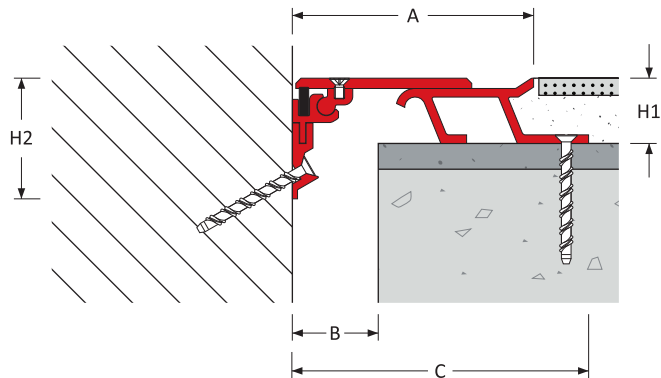

Expansion Joint Selection Criteria

Load Rating

Product Details

Joint Location	Gap B	Movement Capacity (mm)		Eurocode Rating				Product Dimensions			Product Number	
		±	[To-					Height		Sight-A		Block-C
								H1 (mm)	H2 (mm)	A (mm)	C (mm)	
Floor - Floor	25	± 12	[25]	20 kN	190 kN	30 kN	300 kN	25: 38: 50	-	126	190	340-S01-025-(H1)
	50	± 25	[50]	10 kN	100 kN					200 kN	139	203
	75	± 37	[75]		5 kN	46 kN	120 kN				187	242
	100	± 50	[100]	-		31 kN				-	216	280
	150	± 75	[150]		-	-	-				308	372
	200	± 100	[200]	-						-	-	408
	250	± 125	[250]		-	-	-					522
	300	± 150	[300]	-						-	-	622
Floor - Wall	25	± 12	[25]		20 kN	190 kN	30 kN	300 kN	25: 38: 50			70
	50	± 25	[50]	10 kN	100 kN	200 kN				141	173	
	75	± 37	[75]		5 kN		46 kN	120 kN		188	220	
	100	± 50	[100]	-		31 kN	-			226	258	
	150	± 75	[150]		-	-		-		298	330	
	200	± 100	[200]	-			-			-	373	
	250	± 125	[250]		-	-		-			448	
	300	± 150	[300]	-			-			-	523	

When specifying or ordering please add the **height (H1)** required to the Product Reference.
For example MegAtec 340 : S01-100-038 denotes a joint 38mm high.

Features

Surface

80-grit surface finish to stainless steel for improved slip resistance
Americans with Disabilities Act (ADA) compliant
across the entire movement cycle

Movement

Seismic movement capacity
ASTM E-1399 Class I: Thermal
Class II: Wind
Class III: Seismic

Traffic Frequency per day

				
> 25,000	≤ 1,000	≤ 1,000	≤ 1,000	≤ 100

System Options

Gap width(s)	25, 50, 75, 100, 150, 200, 250, 300 mm
Height(s)	25, 38, 50 mm
Metal type(s)	Aluminium Stainless Steel Top Plate
Seal colour(s)	No seal used
Fire barrier	120-240 minutes
Waterproofing	Moisture barrier
Pre-assembly in factory	Contact Vexcolt

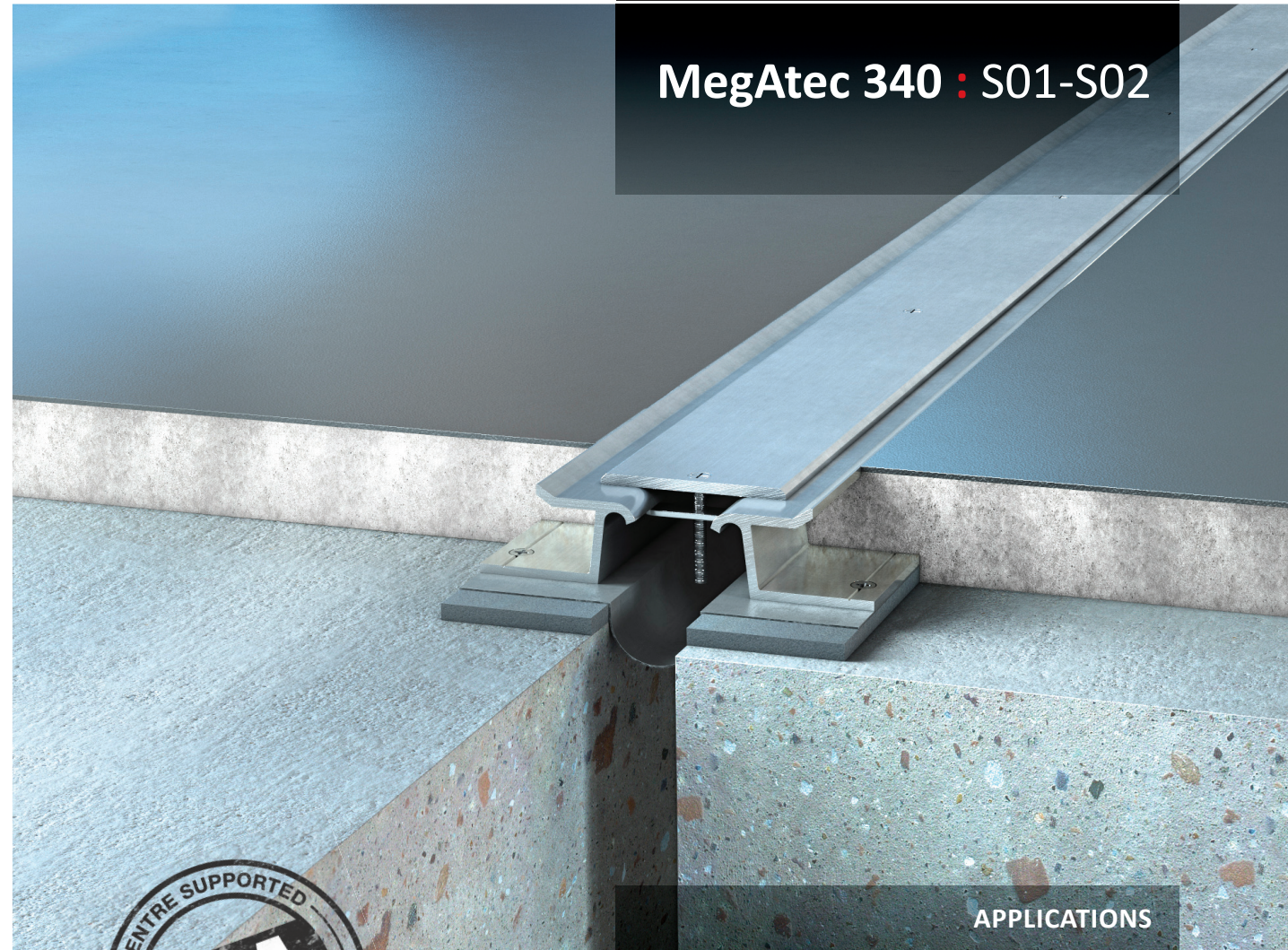

MegAtec 340 : S01-S02



APPLICATIONS

Airport Terminals | Educational | Exhibition Centres
Department Stores | Distribution & Retail Warehouses
Factories | Hospitals | Museums | Offices & Hotels
Parking | Places of Worship | Residential Buildings
Rail, Metros & Elevated Rail Stations | Roads & Bridges
Shopping Centres | Sports Stadiums | Supermarkets