

METAL EXPANSION JOINT

Floor to Floor | Floor to Wall

25 - 150 mm (2 - 6") Expansion Gaps

MegAtec 370 : A01-A02

MegAtec 370 : A01

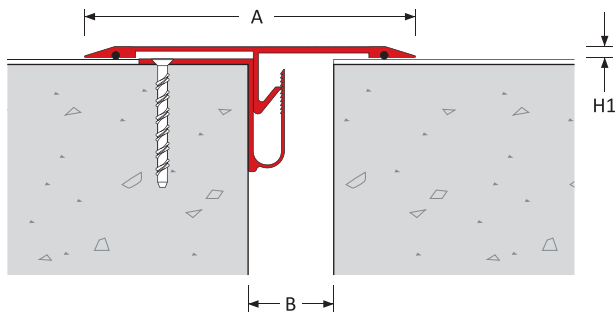

MegAtec 370 : A02

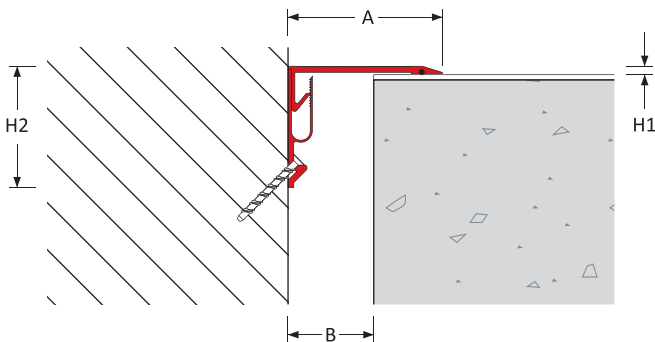

Expansion Joint Selection Criteria

Load Rating

Product Details

Joint Location	Gap Width B(mm)	Movement Capacity (mm)		Eurocode Rating				Product Dimensions			Product Number	
		±	[Total]					Height H1 (mm)	Height H2 (mm)	Sightline A (mm)		Blockout C (mm)
Floor - Floor	25	± 12	[25]	5 kN	31 kN	30 kN	-	6	-	157	-	370-A01-025-(H1)
	50	± 25	[50]							193		370-A01-050-(H1)
	75	± 37	[75]							231		370-A01-075-(H1)
	100	± 50	[100]							268		370-A01-100-(H1)
	150	± 75	[150]							343		370-A01-150-(H1)
Floor - Wall	25	± 12	[25]	5 kN	31 kN	30 kN	-	6	38	62	-	370-A02-025-(H1)
	50	± 25	[50]							98		370-A02-050-(H1)
	75	± 37	[75]						106	135		370-A02-075-(H1)
	100	± 50	[100]							173		370-A02-100-(H1)
	150	± 75	[150]							248		370-A02-150-(H1)

Features

Surface

Hairline serrated surface for improved slip resistance
Americans with Disabilities Act (ADA) compliant
across the entire movement cycle

Movement

High movement capacity
ASTM E-1399 Class I: Thermal
Class II: Wind

Traffic Frequency per day

				
≤ 10,000	≤ 10	≤ 10	-	-

System Options

Gap width(s)	25, 50, 75, 100, 150 mm
Height(s)	6 mm
Metal type(s)	Aluminium
Seal colour(s)	No seal used
Fire barrier	120-240 minutes
Waterproofing	Moisture barrier
Pre-assembly in factory	Contact Vexcolt

MegAtec 370 : A01-A02



APPLICATIONS

Airport Terminals | Educational | Exhibition Centres
Department Stores | Distribution & Retail Warehouses
Factories | Hospitals | Museums | Offices & Hotels
Parking | Places of Worship | Residential Buildings
Rail, Metros & Elevated Rail Stations | Roads & Bridges
Shopping Centres | Sports Stadiums | Supermarkets