

SEISMIC EXPANSION JOINT

Floor to Floor | Floor to Wall

50 - 500 mm (2 - 20") Expansion Gaps

SeismAtec 420 : A01-A02

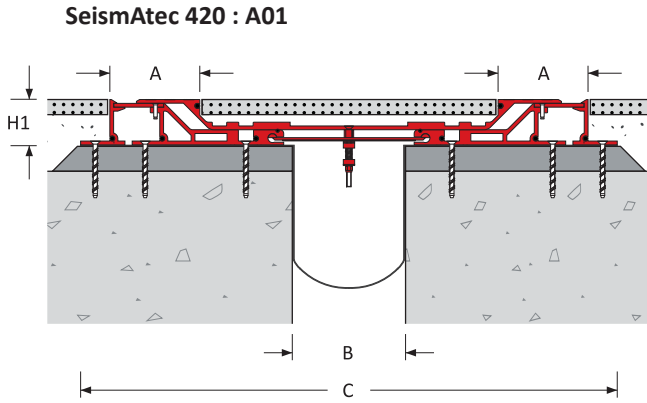

SeismAtec 420 : A01

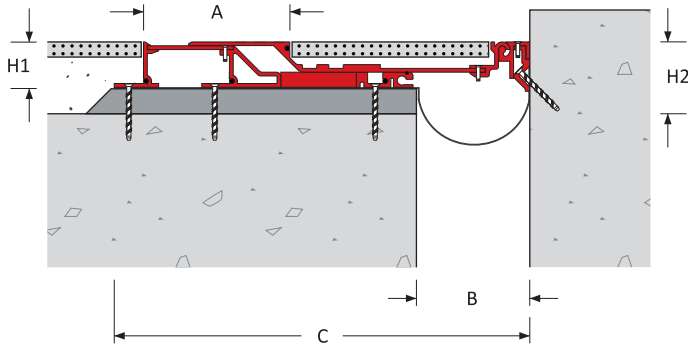

SeismAtec 420 : A02

Expansion Joint Selection Criteria

Load Rating

Product Details

Joint Location	Gap Width B(mm)	Movement Capacity (mm)		Eurocode Rating				Product Dimensions			Product Number		
		Thermal ±	[Total]	Seismic ±	[Total]					Height H1(mm)		H2(mm)	Sightline A (mm)
Floor - Floor	50	± 50	[100]	+50/-35	[85]	20 kN	69 kN	30 kN	50: 60	-	119	611	420-A01-050-(H1)
	75			±50.0	[100]							636	420-A01-075-(H1)
	100			±50.0	[100]							661	420-A01-100-(H1)
	150			±75.0	[150]	711	420-A01-150-(H1)						
	200			±100	[200]	761	420-A01-200-(H1)						
	250			±125	[250]	811	420-A01-250-(H1)						
	300			±150	[300]	861	420-A01-300-(H1)						
	400			±200	[400]	1061	420-A01-400-(H1)						
	500			±250	[500]	1191	420-A01-500-(H1)						
Floor - Wall	50	± 50	[100]	±50.0	[100]	20 kN	69 kN	30 kN	50: 60	66	194	417	420-A02-050-(H1)
	75			±50.0	[100]							490	420-A02-075-(H1)
	100			±50.0	[100]							500	420-A02-100-(H1)
	150			±75.0	[150]	550	420-A02-150-(H1)						
	200			±100	[200]	631	420-A02-200-(H1)						
	250			±125	[250]	706	420-A02-250-(H1)						
	300			±150	[300]	781	420-A02-300-(H1)						
	400			±200	[400]	931	420-A02-400-(H1)						
	500			±250	[500]	1081	420-A02-500-(H1)						

- a. 50mm deep systems are only suitable for the installation of 10mm deep paving within the central pan
- b. 60mm deep systems are suitable for the installation of paving up to 20mm deep within the central pan

Features

Surface

Smooth transit central pan system

Movement

Seismic movement capacity

ASTM E-1399 Class I: Thermal

Class II: Wind

Class III: Seismic

Thermal & Wind movement: +/-50mm

Seismic movement: +/-50% of expansion gap width

Traffic Frequency per day

				
> 25,000	≤ 1,000	≤ 1,000	≤ 100	-

System Options

Gap width(s)	50, 75, 100, 150, 200, 250, 300, 400, 500 mm
Height(s)	50, 60 mm
Metal type(s)	Aluminium
Seal colour(s)	NA
Fire barrier	120-240 minutes
Waterproofing	Waterproofing membrane
Pre-assembly in factory	Contact Vexcolt



SeismAtec 420 : A01-A02

APPLICATIONS

Airport Terminals | Educational | Exhibition Centres
 Department Stores | Distribution & Retail Warehouses
 Factories | Hospitals | Museums | Offices & Hotels
 Parking | Places of Worship | Residential Buildings
 Rail, Metros & Elevated Rail Stations | Roads & Bridges
 Shopping Centres | Sports Stadiums | Supermarkets