

SEISMIC EXPANSION JOINT

Floor to Floor | Floor to Wall

50 - 500 mm (2 - 20") Expansion Gaps

SeismAtec 440 : A01-A02

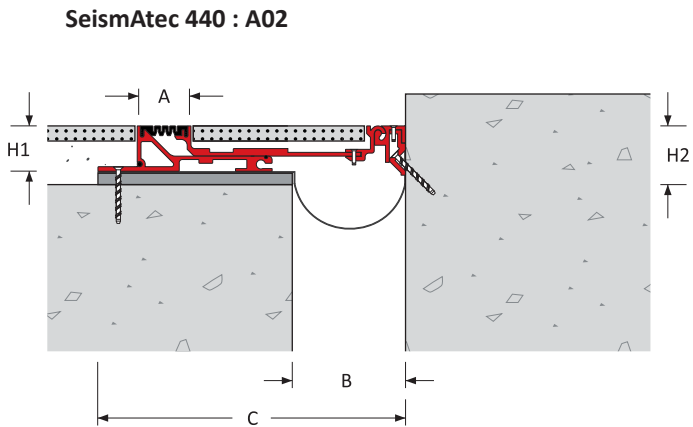
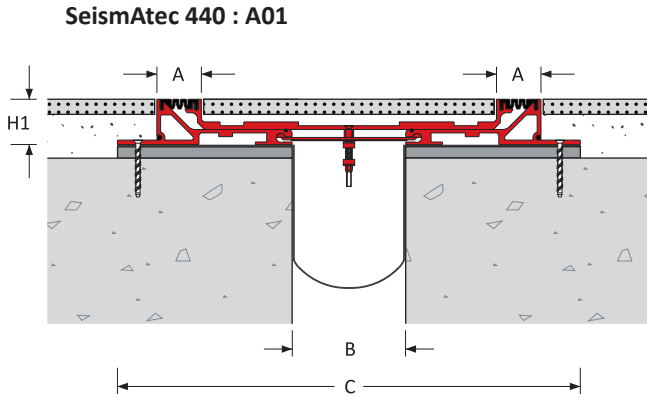

Expansion Joint Selection Criteria

Load Rating

Product Details

Joint Location	Gap Width B(mm)	Movement Capacity (mm)		Eurocode Rating				Product Dimensions			Product Number		
		Thermal ±	[Total]	Seismic ±	[Total]					Height H1(mm)		H2(mm)	Sightline A (mm)
Floor - Floor	50	± 25.0	[50]	±25.0	[50]	20 kN	69 kN	30 kN	50:60	-	59	511	440-A01-050-(H1)
	75			±37.5	[75]							536	440-A01-075-(H1)
	100			±50.0	[100]							561	440-A01-100-(H1)
	150			±75.0	[150]	10 kN	46 kN					611	440-A01-150-(H1)
	200			±100	[200]							661	440-A01-200-(H1)
	250			±125	[250]							715	440-A01-250-(H1)
	300			±150	[300]	5 kN	36 kN					928	440-A01-300-(H1)
	400			±200	[400]							1028	440-A01-400-(H1)
	500			±250	[500]							1128	440-A01-500-(H1)
Floor - Wall	50	± 25.0	[50]	±25.0	[50]	20 kN	69 kN	30 kN	50:60	74	71	343	440-A02-050-(H1)
	75			±37.5	[75]							346	440-A02-075-(H1)
	100			±50.0	[100]							363	440-A02-100-(H1)
	150			±75.0	[150]	10 kN	46 kN					407	440-A02-150-(H1)
	200			±100	[200]							506	440-A02-200-(H1)
	250			±125	[250]							557	440-A02-250-(H1)
	300			±150	[300]	5 kN	36 kN					657	440-A02-300-(H1)
	400			±200	[400]							807	440-A02-400-(H1)
	500			±250	[500]							957	440-A02-500-(H1)

- a. 50mm deep systems are only suitable for the installation of 10mm deep paving within the central pan
- b. 60mm deep systems are suitable for the installation of paving up to 20mm deep within the central pan

Features

Surface

Smooth transit central pan system

Movement

Seismic movement capacity

ASTM E-1399 Class I: Thermal

Class II: Wind

Class III: Seismic

Thermal & Wind movement: +/-25.0mm

Seismic movement: +/-50% of expansion gap width

Traffic Frequency per day

				
> 25,000	≤ 1,000	≤ 1,000	≤ 100	-

System Options

Gap width(s)	50, 75, 100, 150, 200, 250, 300, 400, 500 mm
Height(s)	50, 60 mm
Metal type(s)	Aluminium
Seal colour(s)	Black, Grey, Stone
Fire barrier	120-240 minutes
Waterproofing	Waterproofing membrane
Pre-assembly in factory	Contact Vexcolt



SeismAtec 440 : A01-A02

APPLICATIONS

Airport Terminals | Educational | Exhibition Centres
Department Stores | Distribution & Retail Warehouses
Factories | Hospitals | Museums | Offices & Hotels
Parking | Places of Worship | Residential Buildings
Rail, Metros & Elevated Rail Stations | Roads & Bridges
Shopping Centres | Sports Stadiums | Supermarkets