

SINGLE-SEAL EXPANSION JOINT

Wall to Wall | Corner to Wall

50 - 100 mm (2 - 4") Expansion Gaps

Maxatec 111 : A07-A09

Maxatec 111 : A07

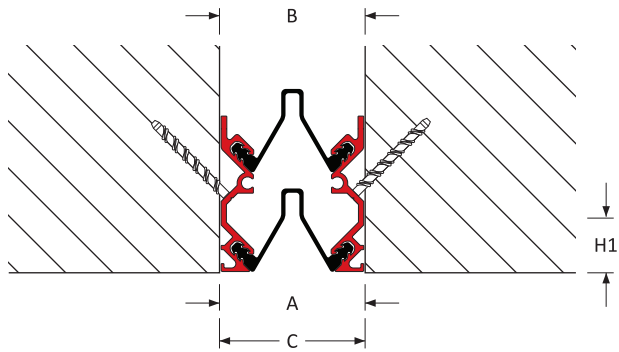

Maxatec 111 : A09

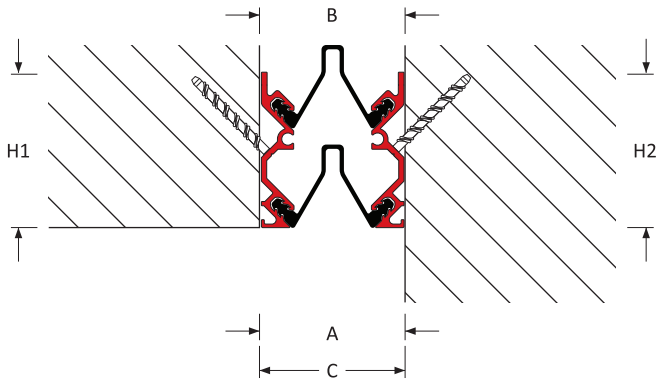

Expansion Joint Selection Criteria

Load Rating

Product Details

Joint Location	Gap Width B(mm)	Movement Capacity (mm)		Eurocode Rating				Product Dimensions		Sightline A (mm)	Blockout C (mm)	Product Number
		±	[Total]					H1 (mm)	H2 (mm)			
Wall - Wall	50	± 25	[50]	-	-	-	-	55	-	50	50	111-A07-050
	75	± 37	[75]	-	-	-	-		75	75	111-A07-075	
	100	± 50	[100]	-	-	-	-		100	100	111-A07-100	
Corner - Wall	50	± 25	[50]	-	-	-	-	55	55	50	50	111-A09-050
	75	± 37	[75]	-	-	-	-		75	75	111-A09-075	
	100	± 50	[100]	-	-	-	-		100	100	111-A09-100	

Features

Surface

Ribbed surface for improved movement
 Double layer rubber

Movement

Good movement capacity
 ASTM E-1399 Class I: Thermal
 Class II: Wind
 Class III: Seismic

Traffic Frequency per day

				
-	-	-	-	-

System Options

Gap width(s)	50, 75, 100 mm
Height(s)	55 mm
Metal type(s)	6063 T5 & T6 Aluminium
Seal colour(s)	Black (RAL 7021) Grey (RAL 7038) Beige (RAL 1015)
Fire barrier	120 minutes
Waterproofing	Moisture Barrier
Aluminium Finish	25 micron clear satin anodised
Pre-assembly in factory	Contact Vexcolt



Maxatec 111 : A07-A09

APPLICATIONS

Airport Terminals | Educational | Exhibition Centres
 Department Stores | Distribution & Retail Warehouses
 Factories | Hospitals | Museums | Offices & Hotels
 Parking | Places of Worship | Residential Buildings
 Rail, Metros & Elevated Rail Stations | Roads & Bridges
 Shopping Centres | Sports Stadiums | Supermarkets