

## EXTERNAL CENTRE PLATE EXPANSION JOINT

Roof to Roof | Roof to Wall

25 - 300 mm ( 1 - 12" ) Expansion Gaps

# MegAtec 610 : A01-A02

MegAtec 610 : A01

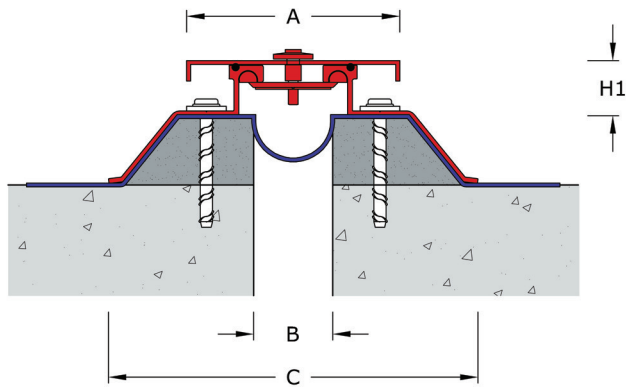

MegAtec 610 : A02

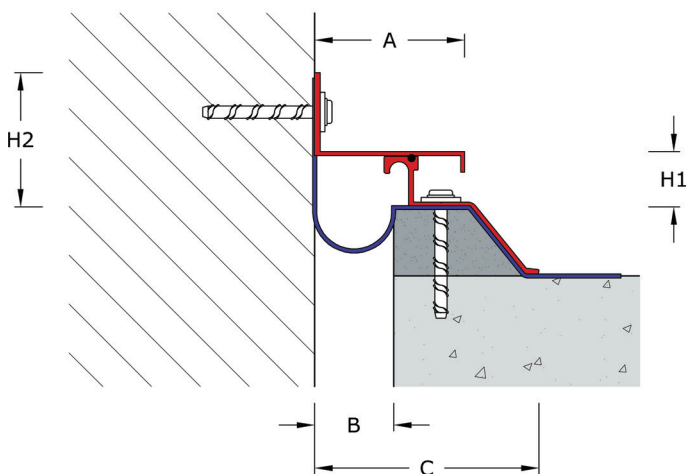

### Expansion Joint Selection Criteria

### Load Rating

### Product Details

Joint Location	Gap Width B (mm)	Movement Capacity (mm)		Eurocode Rating				Product Dimensions Height		Sightline A (mm)	Blockout C (mm)	Product Number
		±	[Total]					H1 (mm)	H2 (mm)			
Roof - Roof	25	± 12	[24]	-	-	-	-	35	-	120	219	610-A01-025-035
	50	± 25	[50]	-	-	-	-			135	234	610-A01-050-035
	75	± 37.5	[75]	-	-	-	-			160	259	610-A01-075-035
	100	± 50	[100]	-	-	-	-			186	284	610-A01-100-035
	150	± 75	[150]	-	-	-	-			262	336	610-A01-150-035
	200	± 100	[200]	-	-	-	-			336	384	610-A01-200-035
	250	± 125	[250]	-	-	-	-			412	434	610-A01-250-035
	300	± 150	[300]	-	-	-	-	488	484	610-A01-300-035		
Roof - Wall	25	± 12	[24]	-	-	-	-	35	53	68	118	610-A02-025-025
	50	± 25	[50]	-	-	-	-			95	142	610-A02-050-025
	75	± 37.5	[75]	-	-	-	-			131	167	610-A02-075-025
	100	± 50	[100]	-	-	-	-			170	192	610-A02-100-025
	150	± 75	[150]	-	-	-	-			245	242	610-A02-150-025
	200	± 100	[200]	-	-	-	-			320	292	610-A02-200-025
	250	± 125	[250]	-	-	-	-			395	342	610-A02-250-025
		300	± 150	[300]	-	-	-			-	470	392

## Features

### Surface

Raised surface

### Movement

Seismic movement capacity

ASTM E-1399 Class I: Thermal

Class II: Wind

Class III: Seismic

## Traffic Frequency per day



- - - - -

## System Options

Gap width(s)	25, 50, 75, 100, 150, 200, 300 mm
Height(s)	35 mm
Metal type(s)	6063 T5 & T6 Aluminium
Fire barrier	120 minutes
Waterproofing	Moisture barrier
Pre-assembly in factory	Contact Vexcolt

# MegAtec 610 : A01-A02

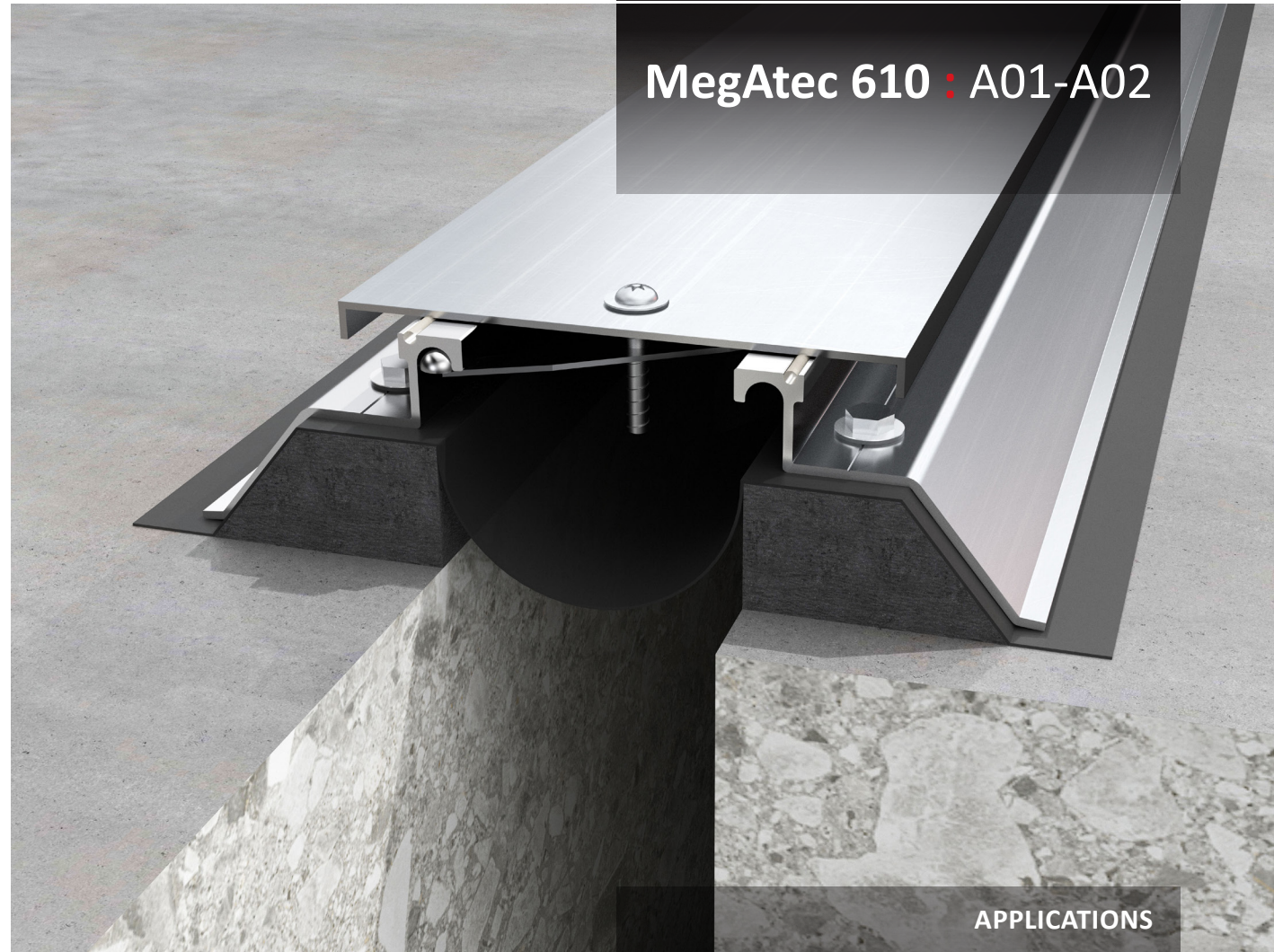

## APPLICATIONS

Airport Terminals | Educational | Exhibition Centres  
 Department Stores | Distribution & Retail Warehouses  
 Factories | Hospitals | Museums | Offices & Hotels  
 Parking | Places of Worship | Residential Buildings  
 Rail, Metros & Elevated Rail Stations | Roads & Bridges  
 Shopping Centres | Sports Stadiums | Supermarkets