

EXTERNAL CENTRE PLATE EXPANSION JOINT

Wall to Wall | Wall to Corner

25 - 300 mm (1 - 12") Expansion Gaps

MegAtec 610 : A07-A09

MegAtec 610 : A07

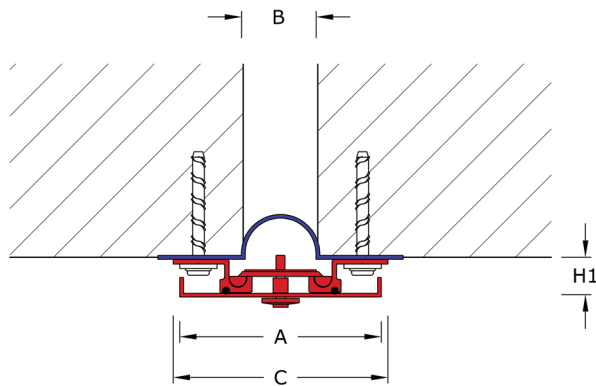

MegAtec 610 : A09

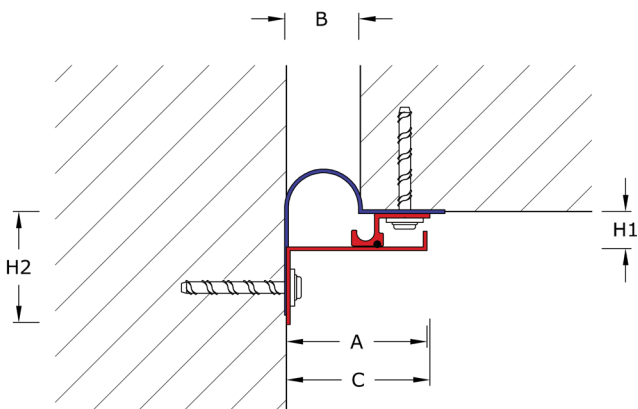

Expansion Joint Selection Criteria

Load Rating

Product Details

Joint Location	Gap Width B (mm)	Movement Capacity (mm)		Eurocode Rating				Product Dimensions		Sightline A (mm)	Blockout C (mm)	Product Number
		±	[Total]					Height H1 (mm)	Height H2 (mm)			
Wall - Wall	25	± 12	[24]	-	-	-	-	25	-	120	129	610-A07-025-025
	50	± 25	[50]	-	-	-	-		135	144	610-A07-050-025	
	75	± 37.5	[75]	-	-	-	-		160	169	610-A07-075-025	
	100	± 50	[100]	-	-	-	-		186	194	610-A07-100-025	
	150	± 75	[150]	-	-	-	-		262	244	610-A07-150-025	
	200	± 100	[200]	-	-	-	-		336	294	610-A07-200-025	
	250	± 125	[250]	-	-	-	-		412	344	610-A07-250-025	
	300	± 150	[300]	-	-	-	-		488	394	610-A07-300-025	
Wall - Corner	25	± 12	[24]	-	-	-	-	25	53	68	72	610-A09-025-025
	50	± 25	[50]	-	-	-	-			95	97	610-A09-050-025
	75	± 37.5	[75]	-	-	-	-			131	122	610-A09-075-025
	100	± 50	[100]	-	-	-	-			170	147	610-A09-100-025
	150	± 75	[150]	-	-	-	-			245	197	610-A09-150-025
	200	± 100	[200]	-	-	-	-			320	247	610-A09-200-025
	250	± 125	[250]	-	-	-	-			395	297	610-A09-250-025
	300	± 150	[300]	-	-	-	-			470	392	610-A09-300-025

Features

Surface

Raised surface

Movement

Seismic movement capacity

ASTM E-1399 Class I: Thermal

Class II: Wind

Class III: Seismic

Traffic Frequency per day



- - - - -

System Options

Gap width(s) 25, 50, 75, 100, 150, 200, 300 mm

Height(s) 25 mm

Metal type(s) 6063 T5 & T6 Aluminium

Fire barrier 120 minutes

Waterproofing Moisture barrier

Pre-assembly in factory Contact Vexcolt



MegAtec 610 : A07-A09

APPLICATIONS

Airport Terminals | Educational | Exhibition Centres
 Department Stores | Distribution & Retail Warehouses
 Factories | Hospitals | Museums | Offices & Hotels
 Parking | Places of Worship | Residential Buildings
 Rail, Metros & Elevated Rail Stations | Roads & Bridges
 Shopping Centres | Sports Stadiums | Supermarkets