

## METAL EXPANSION JOINT

Wall to Wall | Corner & Ceiling to Wall  
25 - 200 mm ( 1 - 8" ) Expansion Gaps

# MegAtec 360 : A07-A09

### MegAtec 360 : A07

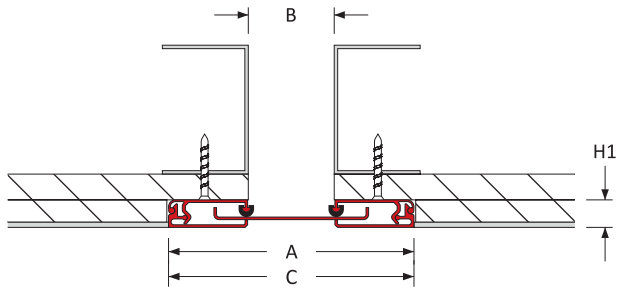

### MegAtec 360 : A09

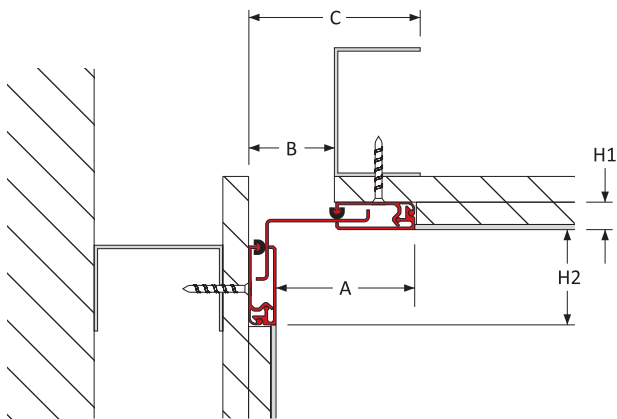

### Expansion Joint Selection Criteria

### Load Rating

### Product Details

Joint Location	Gap Width B (mm)	Movement Capacity (mm)		Eurocode Rating				Product Dimensions		Sightline A (mm)	Blockout C (mm)	Product Number
		±	[Total]					Height H1 (mm)	H2 (mm)			
Wall - Wall	25	± 12	[25]	-	-	-	-	16	-	118	118	360-A07-025-016
	50	± 25	[50]	-	-	-	-			143	143	360-A07-050-016
	75	± 37	[75]	-	-	-	-			197	197	360-A07-075-016
	100	± 50	[100]	-	-	-	-			246	246	360-A07-100-016
	150	± 75	[150]	-	-	-	-			347	347	360-A07-150-016
	200	± 100	[200]	-	-	-	-			448	448	360-A07-200-016
Corner & Ceiling - Wall	25	± 6	[12]	-	-	-	-	16	72	56	72	360-A09-025-016
	50	± 12	[25]	-	-	-	-			81	97	360-A09-050-016
	75	± 19	[37]	-	-	-	-			121	137	360-A09-075-016
	100	± 25	[50]	-	-	-	-			158	174	360-A09-100-016
	150	± 37	[75]	-	-	-	-			234	250	360-A09-150-016
	200	± 50	[100]	-	-	-	-			310	326	360-A09-200-016

## Features

### Surface

No visible fixings

### Movement

High movement capacity

Seismic movement capacity

ASTM E-1399 Class I: Thermal

Class II: Wind

Class III: Seismic

## Traffic Frequency per day



- - - - -

## System Options

Gap width(s) 25, 50, 75, 100, 150, 200 mm

Height(s) 16 mm

Metal type(s) 6063 T5 & T6 Aluminium

Colour(s) 20/25 micron clear satin  
anodised finish aluminium

Fire barrier 120 minutes

Waterproofing Moisture barrier

Pre-assembly in factory Contact Vexcolt

# MegAtec 360 : A07-A09



## APPLICATIONS

Airport Terminals | Educational | Exhibition Centres  
 Department Stores | Distribution & Retail Warehouses  
 Factories | Hospitals | Museums | Offices & Hotels  
 Parking | Places of Worship | Residential Buildings  
 Rail, Metros & Elevated Rail Stations | Roads & Bridges  
 Shopping Centres | Sports Stadiums | Supermarkets