

METAL EXPANSION JOINT

Floor to Floor | Floor to Wall

25 - 150 mm (1 - 6") Expansion Gaps

MegAtec 370 : A01-A02

MegAtec 370 : A01

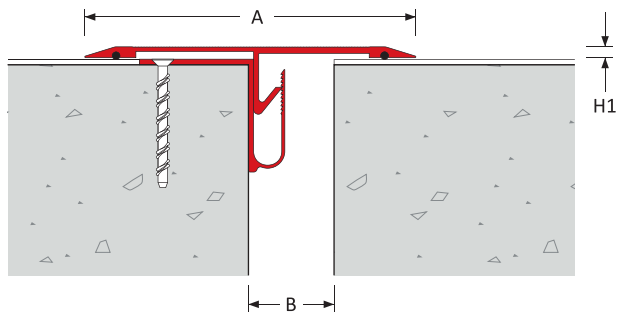

MegAtec 370 : A02

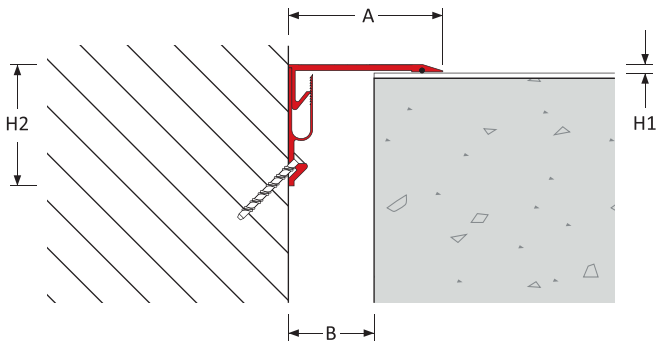

Expansion Joint Selection Criteria

Load Rating

Product Details

Joint Location	Gap Width B (mm)	Movement Capacity (mm)		Eurocode Rating				Product Dimensions				Product Number	
		±	[Total]					Height		Sightline	Blockout		
								H1 (mm)	H2 (mm)	A (mm)	C (mm)		
Floor - Floor	25	± 12	[25]	5 kN	31 kN	30 kN	-	6	-	-	-	157	370-A01-025-006
	50	± 25	[50]									193	370-A01-050-006
	75	± 37	[75]									231	370-A01-075-006
	100	± 50	[100]									268	370-A01-100-006
	150	± 75	[150]									343	370-A01-150-006
Floor - Wall	25	± 12	[25]	5 kN	31 kN	30 kN	-	6	38	-	-	62	370-A02-025-006
	50	± 25	[50]									98	370-A02-050-006
	75	± 37	[75]						106			135	370-A02-075-006
	100	± 50	[100]									173	370-A02-100-006
	150	± 75	[150]									248	370-A02-150-006

MegAtec 370 : A01-A02

Features

Surface

Hairline serrated surface for improved slip resistance
Americans with Disabilities Act (ADA) compliant
across the entire movement cycle

Movement

High movement capacity
ASTM E-1399 Class I: Thermal
Class II: Wind

Traffic Frequency per day

				
≤ 10,000	≤ 10	≤ 10	-	-

System Options

Gap width(s)	25, 50, 75, 100, 150 mm
Height(s)	6 mm
Metal type(s)	6063 T5 & T6 Aluminium
Fire barrier	120 minutes
Waterproofing	Moisture barrier
Pre-assembly in factory	Contact Vexcolt



APPLICATIONS

Airport Terminals | Educational | Exhibition Centres
Department Stores | Distribution & Retail Warehouses
Factories | Hospitals | Museums | Offices & Hotels
Parking | Places of Worship | Residential Buildings
Rail, Metros & Elevated Rail Stations | Roads & Bridges
Shopping Centres | Sports Stadiums | Supermarkets