

## FIRE BARRIER SYSTEM

Floor to Floor | Floor to Wall

25 - 500 mm ( 1 - 20" ) Expansion Gaps

# FireFlex 2200 : A01-A02

FireFlex 2200 : A01-A02

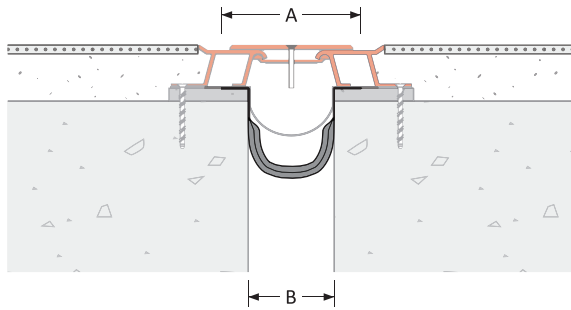

### Fire Barrier Selection Criteria

### Load Rating

### Product Details

Joint Location	Gap Width B (mm)	Movement Capacity (mm)		Eurocode Rating				Product Dimensions			Product Number	
		±	[Total]					Height		Sightline		Blockout
2 Hour Fire Rated (120 mins)												
Floor - Floor	25	± 12	[25]							95		2200-A01-025-2
	50	± 25	[50]							120		2200-A01-050-2
	75	± 37	[75]							145		2200-A01-075-2
	100	± 50	[100]							170		2200-A01-100-2
	125	± 62	[125]							195		2200-A01-125-2
	150	± 75	[150]							220		2200-A01-150-2
	200	± 100	[200]	-	-	-	-	-	-	270	-	2200-A01-200-2
	250	± 125	[250]							320		2200-A01-250-2
	300	± 150	[300]							370		2200-A01-300-2
	350	± 175	[350]							420		2200-A01-350-2
	400	± 200	[400]							470		2200-A01-400-2
	450	± 225	[450]							520		2200-A01-450-2
	500	± 250	[500]							570		2200-A01-500-2
2 Hour Fire Rated (120 mins)												
Floor - Wall	25	± 12	[25]							60		2200-A02-025-2
	50	± 25	[50]							85		2200-A02-050-2
	75	± 37	[75]							110		2200-A02-075-2
	100	± 50	[100]							135		2200-A02-100-2
	125	± 62	[125]							160		2200-A02-125-2
	150	± 75	[150]							185		2200-A02-150-2
	200	± 100	[200]	-	-	-	-	-	-	235	-	2200-A02-200-2
	250	± 125	[250]							285		2200-A02-250-2
	300	± 150	[300]							335		2200-A02-300-2
	350	± 175	[350]							385		2200-A02-350-2
	400	± 200	[400]							435		2200-A02-400-2
	450	± 225	[450]							485		2200-A02-450-2
	500	± 250	[500]							535		2200-A02-500-2

## Features

### Movement

High movement capacity

ASTM E-1399 Class I: Thermal  
 Class II: Wind

### Material

High-temperature refractory ceramic fibre  
 Stainless steel foil sheath

## Traffic Frequency per day



- - - - -

## System Options

Gap width(s)	25, 50, 75, 100, 125, 150, 200, 250, 300, 350, 400, 450, 500 mm
Height(s)	Not applicable
Metal type(s):	Stainless Steel foil
Colour(s)	Stainless Steel sheath
Fire barrier	UL 2079: 120 minutes
Waterproofing	Waterproofing membrane
Pre-assembly in factory	Contact Vexcolt



# FireFlex 2200 : A01-A02

## APPLICATIONS

Airport Terminals | Educational | Exhibition Centres  
 Department Stores | Distribution & Retail Warehouses  
 Factories | Hospitals | Museums | Offices & Hotels  
 Parking | Places of Worship | Residential Buildings  
 Rail, Metros & Elevated Rail Stations | Roads & Bridges  
 Shopping Centres | Sports Stadiums | Supermarkets