

MECHANICAL EXPANSION JOINT

Floor to Floor | Floor to Wall

25 -100 mm (1 - 4") Expansion Gaps

TransAtec 1107 : S01-S02

TransAtec 1107 : S01

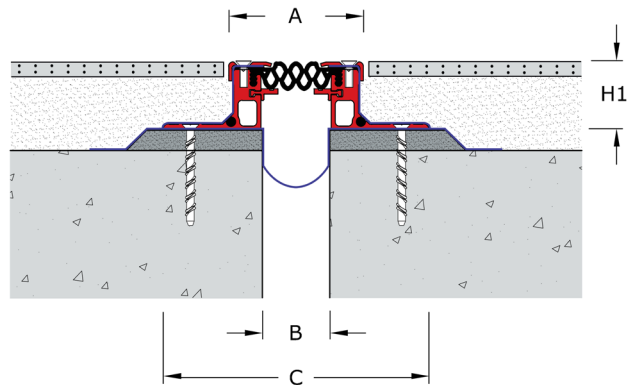

TransAtec 1107 : S02

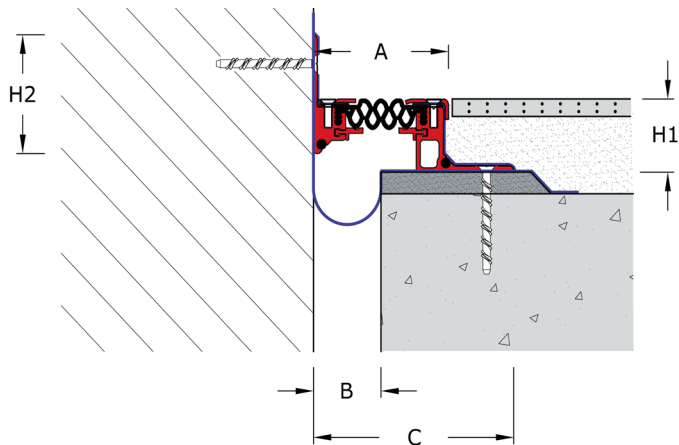

Expansion Joint Selection Criteria

Load Rating

Product Details

Joint Location	Gap Width B (mm)	Movement Capacity (mm)		Eurocode Rating				Product Dimensions		Sightline A (mm)	Blockout C (mm)	Product Number
		±	[Total]					H1 (mm)	H2 (mm)			
Floor - Floor	25	± 10	[20]	5 kN	31 kN	30 kN	630 kN	28: 35: 50: 75: 100	-	75	173	1107-S01-025-(H1)
	50	± 20	[40]							100	198	1107-S01-050-(H1)
	75	± 30	[60]							125	223	1107-S01-075-(H1)
	100	± 40	[80]							150	248	1107-S01-100-(H1)
Floor - Wall	25	± 10	[20]	5 kN	31 kN	30 kN	630 kN	28: 35: 50: 75: 100	82	75	124	1107-S02-025-(H1)
	50	± 20	[40]							100	149	1107-S02-050-(H1)
	75	± 30	[60]							125	174	1107-S02-075-(H1)
	100	± 40	[80]							150	199	1107-S02-100-(H1)

316-grade stainless-steel capping

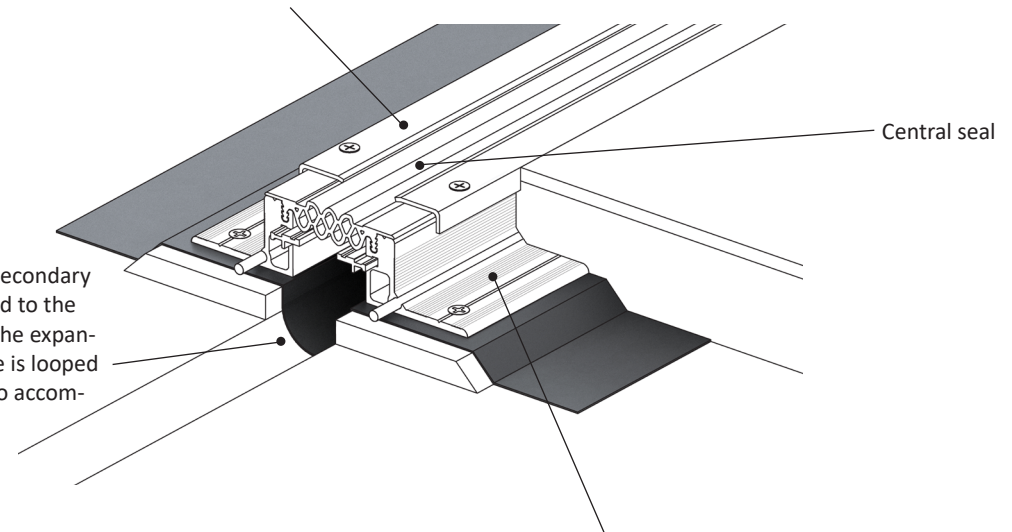

Optional Aquatec 1500 secondary membrane epoxy bonded to the substrate either side of the expansion gap. This membrane is looped into the expansion gap to accommodate movement.

Grade 6063 T6 aluminium frame

Features

Surface

Americans with Disabilities Act (ADA) compliant across the entire movement cycle

Central seal has a ribbed surface for improved slip resistance.

Movement

Good movement capacity

ASTM E-1399 Class I: Thermal

Class II: Wind

Traffic Frequency per day

				
> 25,000	≤ 100	≤ 100	> 25,000	≤ 10

System Options

Gap width(s)	25, 50, 75, 100 mm
Height(s)	28, 35, 50, 75, 100 mm
Metal type(s):	6063 T5 & T6 Aluminium
	316 - Grade stainless steel cappings
Seal colour(s)	Black (RAL 7021)
	Grey (RAL 7038)
Fire barrier	120 minutes
Waterproofing	Waterproofing membrane
Pre-assembly in factory	Contact Vexcolt

TransAtec 1107 : S01-S02



APPLICATIONS

Airport Terminals | Educational | Exhibition Centres
 Department Stores | Distribution & Retail Warehouses
 Factories | Hospitals | Museums | Offices & Hotels
 Parking | Places of Worship | Residential Buildings
 Rail, Metros & Elevated Rail Stations | Roads & Bridges
 Shopping Centres | Sports Stadiums | Supermarkets